

Tools Required

4 ft. level
 Hammer
 Hammer drill
 Misc. screwdriver bits
 Hacksaw
 Misc. drill bits, including 4mm (5/32") & 8mm (5/16")
 6mm (1/4") masonry bit
 11mm (7/16") wrench
 13mm (1/2") wrench
 17mm (11/16") open end wrench
 Chalkline
 152mm (6") shim block
 6-lobe driver bit for upper hinge pin
 Tape measure

M E T A L

CEILING HUNG ELITE INSTALLATION MANUAL



General Notes

The following installation instructions are based on the most common unit arrangement. Other arrangements will be encountered, i.e. units contained between two walls or between two freestanding panels.

For dimensional information, refer to your plan layout and dimensional details. Note in particular the relationship of the panels to the pilasters (panels do not necessarily fall on the centerline of the pilaster).

Ceiling hung toilet partitions require an overhead structural member (normally a channel). This member is supplied, installed, and drilled by others.

Hadrian supplies the stud assemblies but does not install them. Stud assemblies should be in place prior to application of finished ceiling.

Varying site conditions can affect the installation process. To effect a rigid and level installation, it is important for installers to be aware of and compensate for uneven floor and wall conditions.

It is the distributor's responsibility to supply end-users with maintenance and warranty information.

hadrian[™]
toilet partitions and lockers

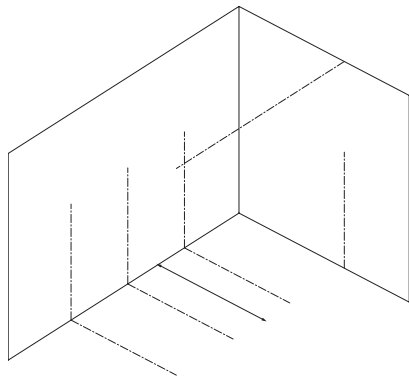

1

Establish Ceiling Stud Locations

Establish front centerline by taking the overall compartment dimension and deducting 16 mm (5/8").

Use final layout drawings to determine locations.

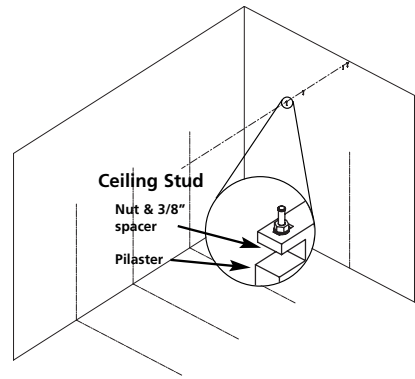

2

Fasten Ceiling Studs

Drill holes for ceiling studs 25mm (1") in from edge of pilaster locations as indicated on layout drawing.

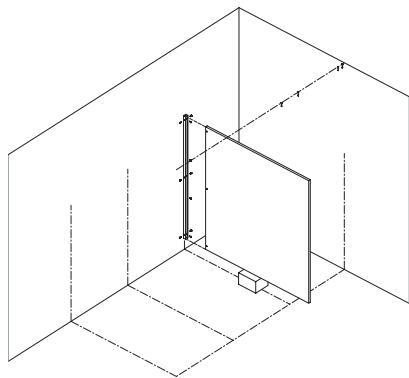

3

Erect Panel

Using your centerline locations, fasten wall channel to wall. The bottom of the channel should be 159mm (6 1/4") from floor.

Rest panel on 152mm (6") block and position in channel, leaving 13mm (1/2") clearance between wall and panel. Drill one hole through top of channel and fasten.

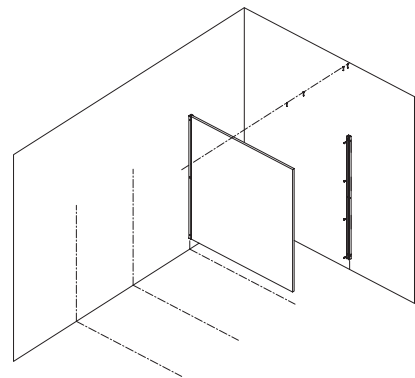

4

Place Pilaster Channel

Fasten channel to wall at centerline. Bottom of channel should be 159mm (6 1/4") from floor.

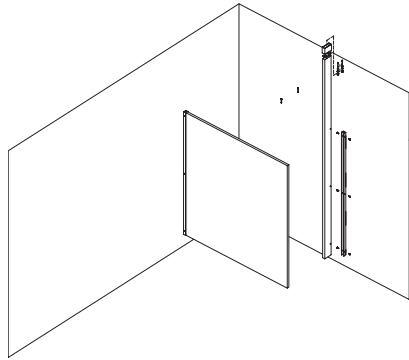

5

Erect Wall Pilaster

Slide shoe onto pilaster. Position pilaster in pilaster channel and over ceiling studs. Install ceiling bracket hardware, plumb pilaster, and tighten. Attach pilaster to channel.

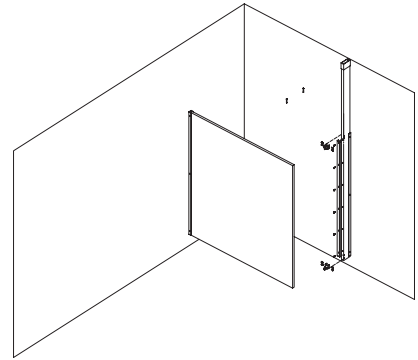

6

Prepare Pilaster For Door

Fasten upper and lower hinges to wall pilaster.

Place hinge side filler between hinges, pre-drill pilaster with 4mm (5/32") pilot holes and install fasteners.

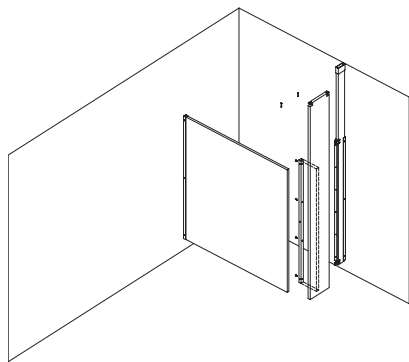

7

Fasten Channel To Pilaster

Place next pilaster on ceiling studs and mark center line of panel on the back. Bottom of channel should be 159mm (6 1/4") from floor. Using the channel as a template, mark drill holes.

Remove pilaster from ceiling studs and fasten channel.

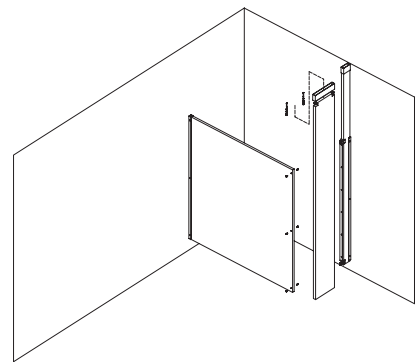

8

Erect Pilaster

Slide shoe onto pilaster and position on ceiling studs with channel engaging panel.

Drill one hole through top of channel and fasten.

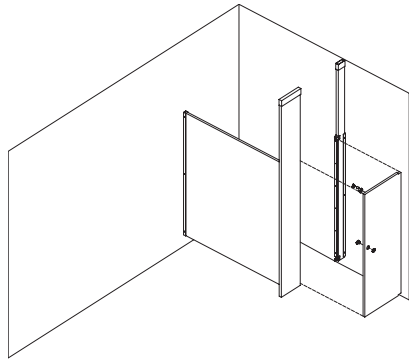

9

Prepare Door For Hanging

Install female cam in the door.

Install latch, and coat hook/bumper.

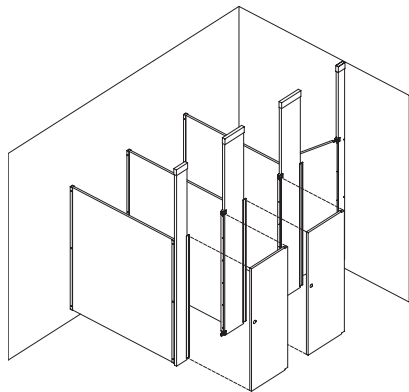

11

Erect Remaining Compartments

Ensure all pilasters are fastened to ceiling studs, add all remaining fasteners and repeat steps 3-11 (as necessary) for all remaining compartments.

Note: Hadrian recommends installing one compartment (including door) at a time.



Optional Item

Continuous Hinge

Replaces conventional hinge and hinge filler

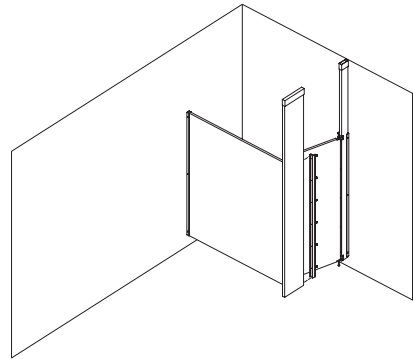

10

Hang Door

Insert male cam into bottom hinge and lower door onto it. Install threaded upper hinge pin. To set doors at the required angle, loosen the nut of the male cam assembly, set door at required angle, and tighten nut.

Place continuous stop on pilaster, ensuring the top lines up with the locking bar seam on top of the door. Pre-drill pilaster with 4mm (5/32") pilot holes and install fasteners.

Contact Hadrian:

IN CANADA & AREAS

OTHER THAN USA & EUROPE:

Hadrian Manufacturing Inc.,
965 Syscon Road,
Burlington, ON L7L 5S3
tel: 905-333-0300
fax: 905-333-1841
CAN toll free fax: 1-888-817-7701

IN THE USA:

Hadrian Inc.,
7420 Clover Ave.,
Mentor, OH 44060
tel: 440-942-9118
fax: 440-942-9618
USA toll free fax: 1-800-536-1469

IN EUROPE:

Hadrian Manufacturing Inc.
Unit 14 Howard Court
Nerston Industrial Estate
East Kilbride, Scotland G74 4QZ
tel: 01355-222270
fax: 01355-222213

Registered in the UK: BR7194 • Head Office registered in the Province of Ontario, Canada. Ontario Corporation Number: 1456606